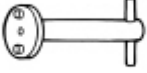

## Brake Pads

### Special Tool(s)

 ST1112-A	Adapter, Rear Brake Caliper Piston Adjuster 206-026 (T87P-2588-A) or equivalent
---	--

### Material

Item	Specification
High Performance DOT 3 Motor Vehicle Brake Fluid PM-1-C (US); CPM-1-C (Canada)	WSS-M6C62-A or WSS-M6C65-A1
Silicone Brake Caliper Grease and Dielectric Compound XG-3-A	ESE-M1C171-A

### Removal

 **WARNING:** Do not use any fluid other than clean brake fluid meeting manufacturer's specification. Additionally, do not use brake fluid that has been previously drained. Following these instructions will help prevent system contamination, brake component damage and the risk of serious personal injury.

 **WARNING:** Carefully read cautionary information on product label. For EMERGENCY MEDICAL INFORMATION seek medical advice. In the USA or Canada on Ford/Motorcraft products call: 1-800-959-3673. For additional information, consult the product Material Safety Data Sheet (MSDS) if available. Failure to follow these instructions may result in serious personal injury.

 **WARNING:** Always install new brake shoes or pads at both ends of an axle to reduce the possibility of brakes pulling vehicle to one side. Failure to follow this instruction may result in uneven braking and serious personal injury.

**NOTICE:** Do not spill brake fluid on painted or plastic surfaces or damage to the surface may occur. If brake fluid is spilled onto a painted or plastic surface, immediately wash the surface with water.

1. Remove the wheel and tire. For additional information, refer to [Section 204-04](#).
2. **NOTICE:** Care must be used when servicing rear brake components without disconnecting the parking brake cable from the brake caliper lever. Carefully position the caliper aside using a suitable support or damage to the parking brake cable end fittings may occur.

**NOTICE:** Do not use caliper sight hole to retract pistons as this may damage the pistons and boots.

**NOTICE:** Do not allow the caliper to hang from the brake hose or damage to the hose may occur.

Remove the 2 brake caliper guide pin bolts and position the brake caliper aside.

- Support the caliper using mechanic's wire.

3. Remove the brake pads and discard the spring clips.
4. Measure the brake disc thickness.
  - Install a new brake disc if not within specification. For additional information, refer to [Brake Disc](#) in this section.
5. Inspect the brake caliper.
  - If leaks or damaged boots are found, install a new brake caliper. For additional information, refer to [Brake Caliper](#) in this section.
6. Inspect the brake caliper anchor plate assembly.
  - Check the guide pins and boots for binding and damage.
  - Replace worn or damaged pins. Lubricate the pins with the specified grease.
  - Install a new brake caliper anchor plate if it is worn or damaged.

## Installation

1. Using the Rear Brake Caliper Piston Adjuster Adapter, compress the brake caliper piston into the brake caliper bore.

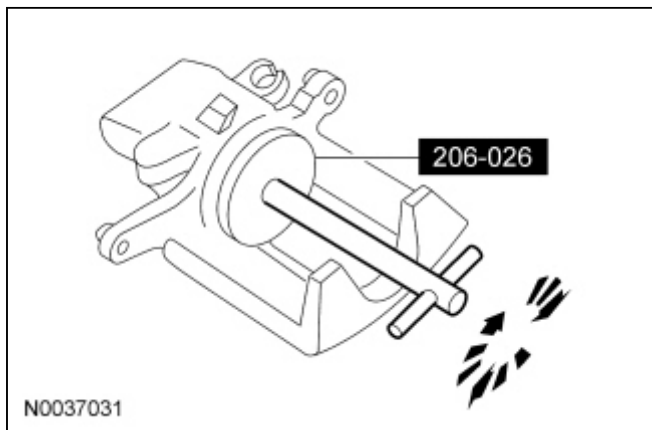

2. Position the notch in the caliper piston up and down to align with the alignment pin on the brake pad.
3. **NOTICE: Do not allow grease, oil, brake fluid or other contaminants to contact the pad lining material, or damage to components may occur. Do not install contaminated pads.**

**NOTE:** Install all hardware supplied with the pad kit.

Install the 2 new spring clips and the brake pads.

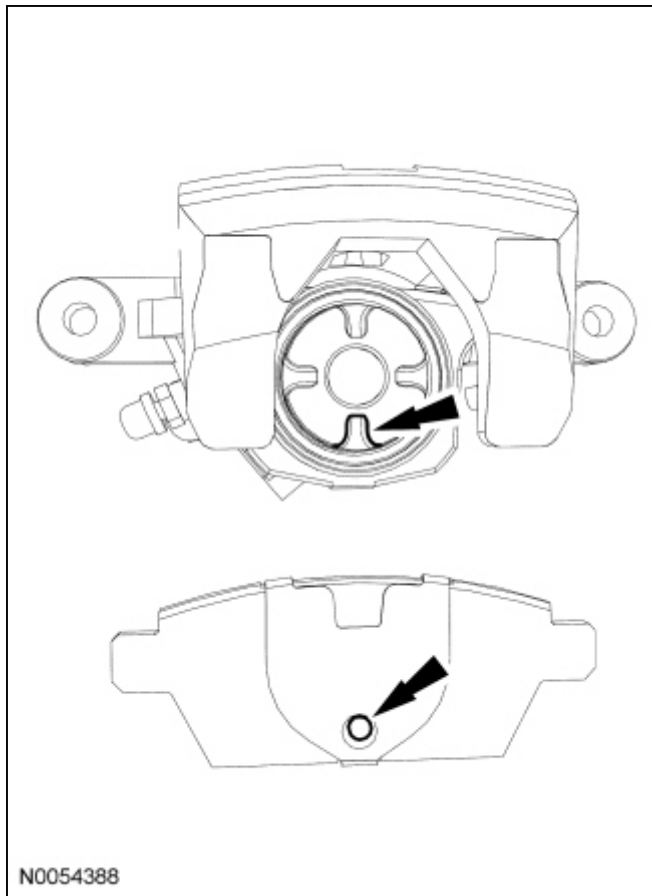

4. Position the brake caliper on the anchor plate and install the 2 brake caliper guide pin bolts until snug.
    - Tighten the RH caliper guide pin bolts in the following sequence:
      - Tighten the top bolt to 33 Nm (24 lb-ft).
      - Tighten the bottom bolt to 33 Nm (24 lb-ft).
    - Tighten the LH caliper guide pin bolts in the following sequence:
      - Tighten the bottom bolt to 33 Nm (24 lb-ft).
      - Tighten the top bolt to 33 Nm (24 lb-ft).
  
  5. Install the wheel and tire. For additional information, refer to [Section 204-04](#).
    - Apply brakes several times to verify correct brake operation.
-

